

NEW

4-Way Equal Load Roller Type LM Guide

HRX



LM Guide suitable for ultra-high rigidity and ultra-heavy loads



Model HRX

Roller Type LM Guide

LM Guide suitable for ultra-high rigidity and ultra-heavy loads

Feature 1 Ultra-High Rigidity and Ultra-Heavy Loads p. 3

The HRX is an LM Guide that uses rollers as a rolling element for higher rigidity. Also, compared to our existing roller products, we have extended the length of the metal LM load block and increased the number of load-bearing rollers to achieve an improved static load rating.

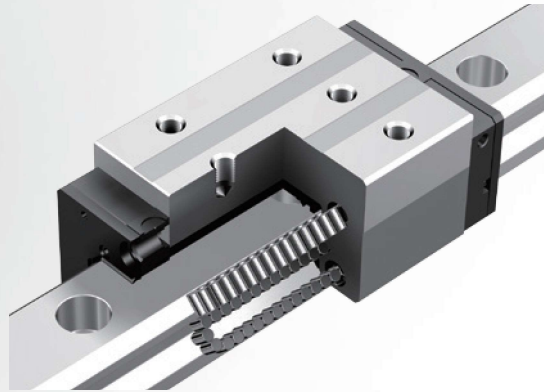

Internal structure of the HRX

Feature 2 4-Way Equal Load p. 3

On the HRX, each row of rollers is arranged at a contact angle of 45° so that the LM block receives an equal load rating in all directions (radial, reverse radial, and horizontal directions), ensuring high rigidity in all directions.

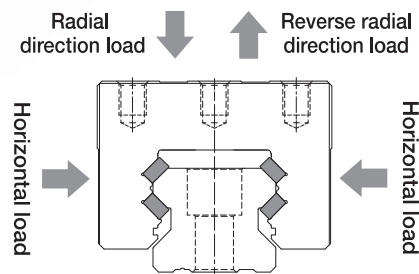

Feature 3 LM Blocks and LM Rails Available for Individual Sale p. 15

The HRX lineup features interchangeable products that can meet specifications by freely combining LM blocks and LM rails of the same model number. See p. 15 for details.



Roller Type LM Guide Model HRX

Feature 1 Ultra-High Rigidity and Ultra-Heavy Loads

For the HRX, in order to achieve an improved basic static load rating, we have extended the length of the metal LM block and increased the number of load-bearing rollers.

LM Block Overall Length and Basic Static Load Rating

| Model No. | | Length of metal LM block L_1 | | Basic static load rating C_0 | |
|-----------|-------|-----------------------------------|-------|-----------------------------------|-------|
| | | Our existing roller products | HRX | Our existing roller products | HRX |
| #25 | C/R | 65,5 | 75,4 | 57,5 | 73,1 |
| | LC/LR | 85,1 | 92,2 | 75 | 89,3 |
| #30 | C/R | 75 | 84 | 82,5 | 104,7 |
| | LC/LR | 99 | 108,5 | 108 | 135,2 |
| #35 | C/R | 82,2 | 92,2 | 119 | 150,1 |
| | LC/LR | 112,2 | 120,2 | 165 | 195,7 |
| #45 | C/R | 107 | 115,7 | 192 | 250,4 |
| | LC/LR | 142 | 150,7 | 256 | 326,7 |
| #55 | C/R | 129,2 | 143,2 | 266 | 369,9 |
| | LC/LR | 179,2 | 192,7 | 366 | 497,9 |
| #65 | C/R | 171,7 | 195,7 | 441 | 567 |
| | LC/LR | 229,8 | 260,7 | 599 | 756 |

Feature 2 4-Way Equal Load

The Model HRX is designed to have an equal basic load rating on the LM block for all four directions.

(*Four directions: radial, reverse radial, left, and right)

As a result, this model can be used in any orientation, enabling a wide variety of applications.

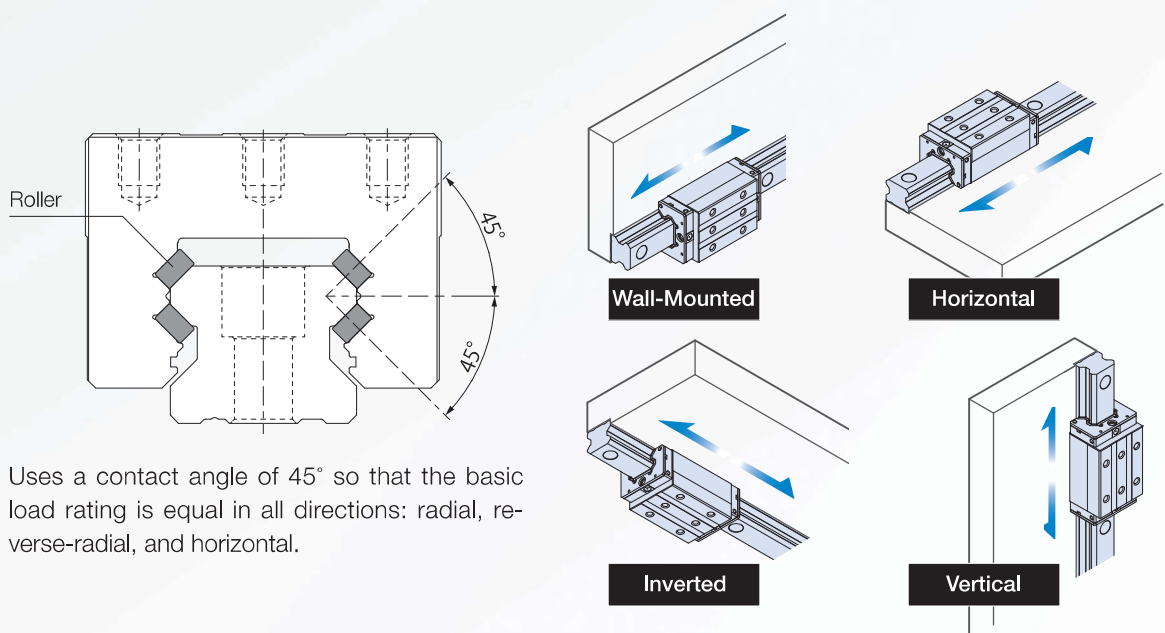

Uses a contact angle of 45° so that the basic load rating is equal in all directions: radial, reverse-radial, and horizontal.

This model is equally suited for use in a horizontal orientation and any other orientation.

Structure of the HRX

The Model HRX features raceways on the sides of the LM rail, which come into contact with the rollers at a 45° angle.

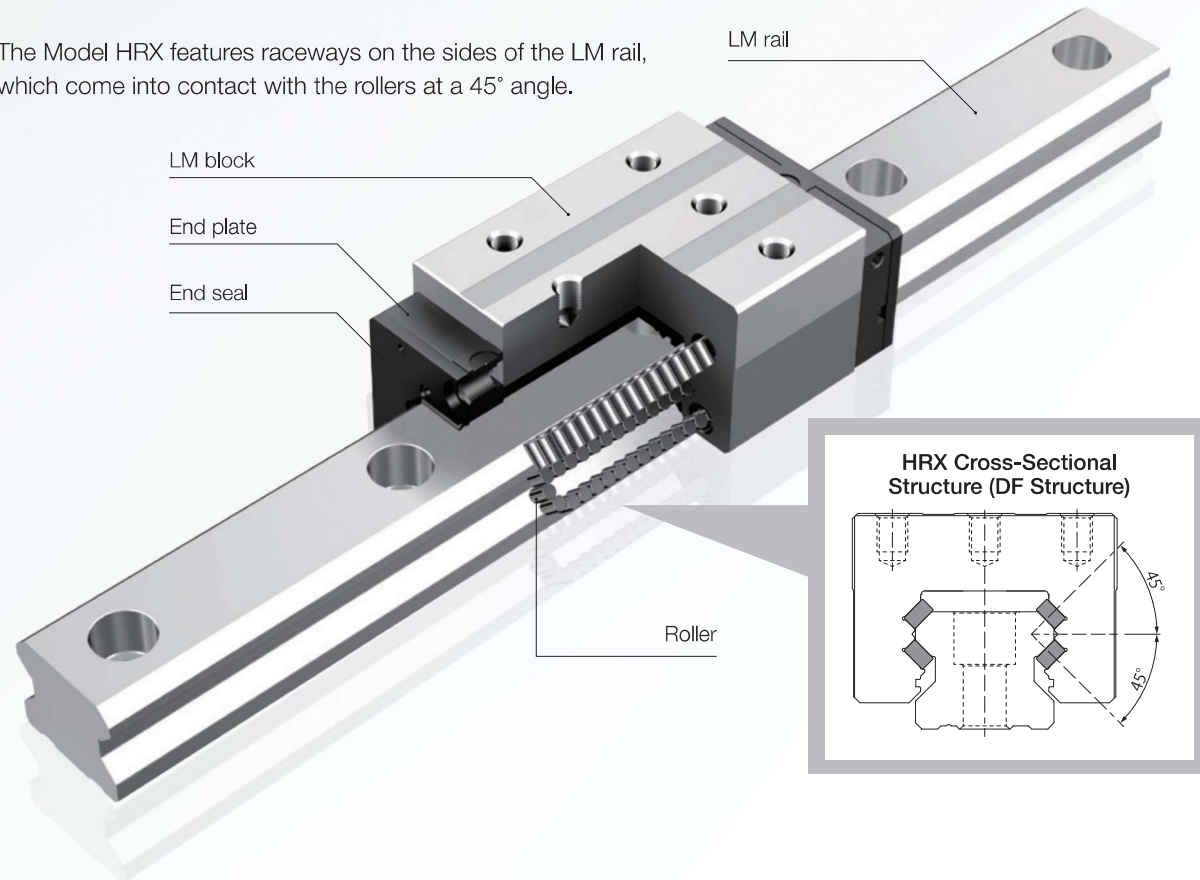

Lineup

The Model HRX comes in six sizes ranging from 25 to 65, and a lineup of four block types is available: C/LC and R/LR. The Model HRX's dimensions conform to world-standard ISO specifications (ISO 12090-1:2011 Rolling Bearings). Only #65R/LR height M differs from ISO dimensions.

Lineup

| Block Type | | HRX25 | HRX30 | HRX35 | HRX45 | HRX55 | HRX65 |
|---------------|----|-------|-------|-------|-------|-------|-------|
| Standard type | R | ○ | ○ | ○ | ○ | ○ | ○ |
| | C | ○ | ○ | ○ | ○ | ○ | ○ |
| Long type | LR | ○ | ○ | ○ | ○ | ○ | ○ |
| | LC | ○ | ○ | ○ | ○ | ○ | ○ |

HRX-C/LC

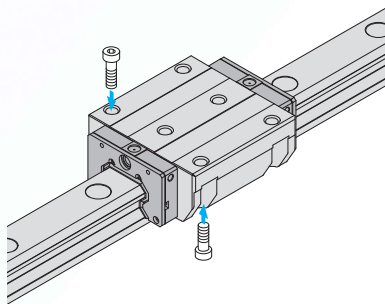

The flange of this LM block has tapped holes. This type can be mounted from the top or the bottom.

HRX-R/LR

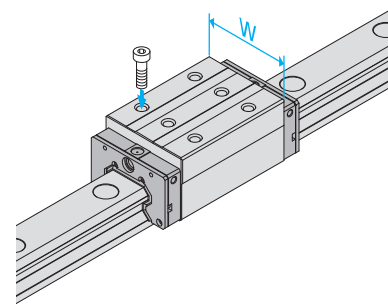

With this type, the LM block has a smaller width (W) and tapped holes. It is ideal for compact designs.

Contamination Protection Accessories

It is necessary to prevent foreign materials from getting inside the product, as it will lead to abnormal wear and a shortened service life. If it is likely that foreign materials will get inside, it is important to select an effective sealing or contamination protection device suited to the environmental conditions.

Seals

End seals made of synthetic rubber that are highly resistant to wear and side seals that further improve dust-proofing effectiveness are available. Use the symbols in the table to the right to specify if you need a contamination protection accessory.

| Symbol | Contamination protection accessories |
|--------|----------------------------------------------------------|
| UU | End seals |
| SS | End seals + side seals + inner seals |
| DD | Double seals + side seals + inner seals |
| ZZ | End seals + side seals + inner seals + metal scrapers |
| KK | Double seals + side seals + inner seals + metal scrapers |

End Seal

Used in locations exposed to dust

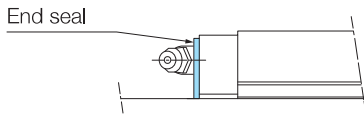

Side Seal

Used in locations where dust may enter the LM block from the side or bottom surfaces, such as vertical, horizontal, and inverted configurations

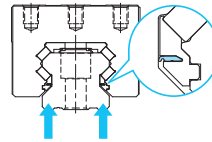

Inner Seal

Used in locations severely exposed to dust or cutting chips

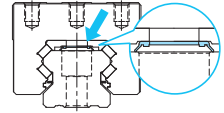

Double Seals

Used in locations exposed to dust

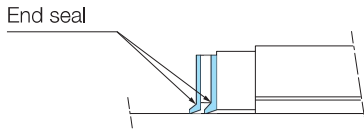

Metal Scraper (Non-Contact)

Used in locations where welding spatter may adhere to the LM rail
Metal scraper

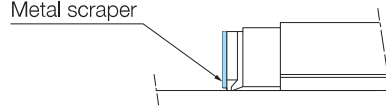

Seal Resistance Value

See the table below for the maximum seal resistance of SS seals per LM block when the product is lubricated.

Unit: N

| Model No. | Seal symbol | Maximum Seal Resistance |
|-----------|-------------|-------------------------|
| HRX25 | SS | 14 |
| HRX30 | | 15 |
| HRX35 | | 18 |
| HRX45 | | 23 |
| HRX55 | | 26 |
| HRX65 | | 32 |

Laminated Contact Scraper LaCS

For locations with an adverse environment, Laminated Contact Scraper LaCS is available.

LaCS removes minute foreign material adhering to the LM rail in multiple stages and prevents it from entering the LM block with a laminated contact structure (3-layer scraper).

Features

- Because the three layers of scrapers fully contact the LM rail, LaCS is highly capable of removing minute foreign material.
- Low friction resistance is achieved through the use of oil-impregnated, self-lubricating synthetic foam rubber.

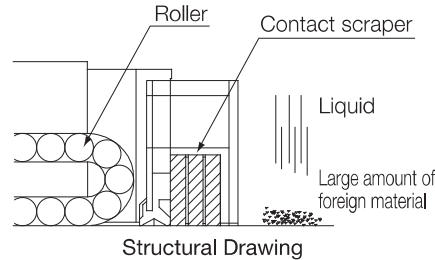

Maximum Resistance Value When LaCS Is Applied

Unit: N

| Model No. | Sliding resistance |
|-----------|--------------------|
| HRX25 | 6.3 |
| HRX30 | 7.2 |
| HRX35 | 13 |
| HRX45 | 18 |
| HRX55 | 25 |
| HRX65 | 34 |

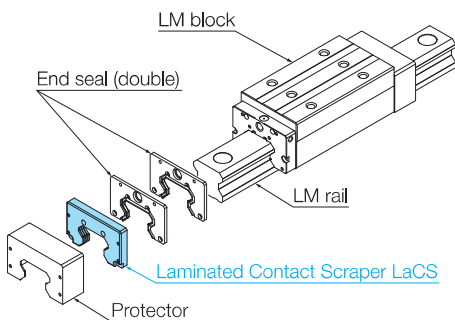

External View

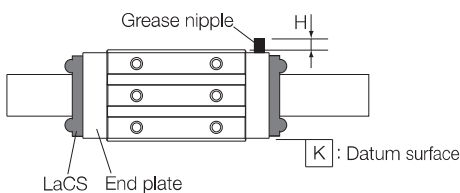

Location for Mounting the Side Grease Nipple

| Symbol | Contamination protection accessories |
|--------|-----------------------------------------------------------------|
| SSHH | End seals + side seals + inner seals + LaCS |
| DDHH | Double seals + side seals + inner seals + LaCS |
| ZZHH | End seals + side seals + inner seals + LaCS + metal scrapers |
| KKHH | Double seals + side seals + inner seals + LaCS + metal scrapers |
| JJHH | End seals + side seals + inner seals + LaCS + protectors |
| TTHH | Double seal + side seals + inner seals + LaCS + protectors |

| Model No. | Dimensional increase with a grease nipple (mm) | |
|-----------|------------------------------------------------|-------------|
| | Side greasing | |
| | H | Nipple type |
| HRX25 | 6.9 | A-M6F |
| HRX30 | 6.9 | |
| HRX35 | 6.7 | |
| HRX45 | 6.7 | |
| HRX55 | 6.2 | |
| HRX65 | 6.2 | |

Protector

The protector minimizes the ingress of foreign material even in harsh environments where foreign material such as fine particles and liquids are present.

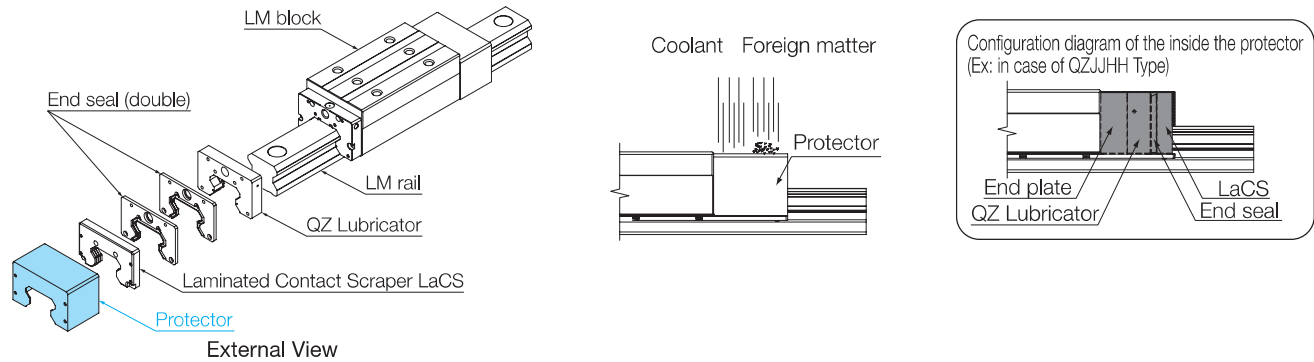

The Overall LM Block Length with LaCS and Seals Attached

Unit: mm

| Symbol | Overall length when options are attached | | | | | | | | | | | |
|-----------|------------------------------------------|--------|-------|--------|-------|--------|-------|--------|-------|--------|-------|--------|
| | HRX25 | HRX25L | HRX30 | HRX30L | HRX35 | HRX35L | HRX45 | HRX45L | HRX55 | HRX55L | HRX65 | HRX65L |
| No Symbol | 94.4 | 111.2 | 104 | 128.5 | 116.2 | 144.2 | 143.7 | 178.7 | 173.2 | 222.7 | 231.7 | 296.7 |
| UU/SS | 99.6 | 116.4 | 110.6 | 135.1 | 123.2 | 151.2 | 150.7 | 185.7 | 180.2 | 229.7 | 239.1 | 304.1 |
| DD | 104.8 | 121.6 | 117.2 | 141.7 | 130.2 | 158.2 | 157.7 | 192.7 | 187.2 | 236.7 | 246.5 | 311.5 |
| ZZ | 104.6 | 121.4 | 115.6 | 140.1 | 131.6 | 159.6 | 159.9 | 194.9 | 189.4 | 238.9 | 250.3 | 315.3 |
| KK | 109.8 | 126.6 | 122.2 | 146.7 | 138.6 | 166.6 | 166.9 | 201.9 | 196.4 | 245.9 | 257.7 | 322.7 |
| SSHH | 117.2 | 134 | 128.2 | 152.7 | 140.8 | 168.8 | 171.3 | 206.3 | 200.8 | 250.3 | 263.1 | 328.1 |
| DDHH | 122.4 | 139.2 | 134.8 | 159.3 | 147.8 | 175.8 | 178.3 | 213.3 | 207.8 | 257.3 | 270.5 | 335.5 |
| ZZHH | 122.2 | 139 | 133.2 | 157.7 | 149.2 | 177.2 | 180.5 | 215.5 | 210 | 259.5 | 274.3 | 339.3 |
| KKHH | 127.4 | 144.2 | 139.8 | 164.3 | 156.2 | 184.2 | 187.5 | 222.5 | 217 | 266.5 | 281.7 | 346.7 |
| JJHH | 122.2 | 139 | 133.2 | 157.7 | 149.2 | 177.2 | 180.3 | 215.3 | 209.8 | 259.3 | 274.1 | 339.1 |
| TTHH | 127.4 | 144.2 | 139.8 | 164.3 | 156.2 | 184.2 | 187.3 | 222.3 | 216.8 | 266.3 | 281.5 | 346.5 |

Dedicated Cap for LM Rail Mounting Holes

Using dedicated caps to cover the LM rail mounting holes helps prevent foreign material from entering the mounting holes and LM block.



CV Cap

The caps are made of a special synthetic resin. The CV cap is the successor to the C cap, and its new structure makes it easier to insert.



| Applicable model | Cap model No. | Used bolts | Main dimensions (mm) | |
|------------------|---------------|------------|----------------------|-----|
| | | | D | H |
| HRX25 | CV6 | M6 | 11,4 | 2,6 |
| HRX30 | CV8 | M8 | 14,4 | 3,3 |
| HRX35 | CV8 | M8 | 14,4 | 3,3 |
| HRX45 | CV12 | M12 | 20,4 | 3,4 |
| HRX55 | CV14 | M14 | 23,4 | 5,5 |
| HRX65 | CV16 | M16 | 26,4 | 5,6 |

GC Cap

GC caps are made of metal. (They are RoHS compliant.) GC caps adhere closer to the counterbore than CV caps, so there is no clearance once they are inserted.

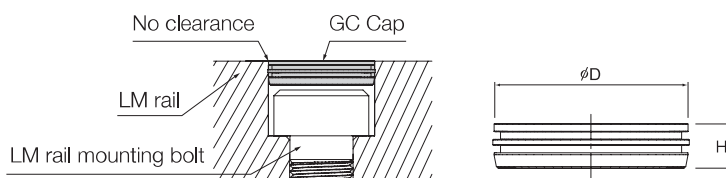

| Applicable model | Cap model No. | Used bolts | Main dimensions (mm) | |
|------------------|---------------|------------|----------------------|-----|
| | | | D | H |
| HRX25 | GC6 | M6 | 11.36 | 2.5 |
| HRX30 | GC8 | M8 | 14.36 | 3.5 |
| HRX35 | GC8 | M8 | 14.36 | 3.5 |
| HRX45 | GC12 | M12 | 20.36 | 4.6 |
| HRX55 | GC14 | M14 | 23.36 | 5.0 |
| HRX65 | GC16 | M16 | 26.36 | 5.0 |

Note 1) GC caps are only sold with an LM Guide. They are not sold separately. The LM Guide model number code will have "GC" at the end when it is delivered.

HRX35 LC 2 UU CO + 1200L P GC GC caps attached

Note 2) GC caps cannot be used with LM rails that have undergone surface treatment.
 Note 3) LM rail mounting holes for GC caps are special. (The mouth is not chamfered.)
 Note 4) Be careful not to injure your hand when inserting GC caps.
 Note 5) Be sure to make the GC caps level with the upper surface of the LM rail and clean (wipe) that surface after insertion.

Lubrication

Standard Grease

AFB-LF Grease is a general-purpose grease that provides excellent extreme pressure and mechanical stability properties through the use of a refined mineral oil base oil and a lithium-based consistency enhancer.

*Non-standard greases are also available. Contact THK for details.

AFB-LF Representative Physical Properties

| Item | Representative physical property | Testing method |
|---------------------------------------------------------|----------------------------------|----------------|
| Consistency enhancer | Lithium-based | |
| Base oil | Refined mineral oil | |
| Base oil kinematic viscosity: mm ² /s (40°C) | 170 | JIS K 2220 23 |
| Worked penetration (25°C, 60 W) | 275 | JIS K 2220 7 |
| Mixing stability (100,000 W) | 345 | JIS K 2220 15 |
| Dropping point: °C | 193 | JIS K 2220 8 |
| Evaporation volume: mass% (99°C, 22 h) | 0.4 | JIS K 2220 10 |
| Oil separation rate: mass% (100°C, 24 h) | 0.6 | JIS K 2220 11 |
| Copper plate corrosion (B method, 100°C, 24 h) | Passed | JIS K 2220 9 |
| Low-temperature torque: mN·m (-20°C) | Starting | JIS K 2220 18 |
| | Rotational | |
| 4-ball testing (welding load): N | 3089 | ASTM D2596 |
| Operating temperature range: °C | -15 to 100 | |
| Color | Yellowish brown | |

QZ Lubricator

The QZ Lubricator feeds the right amount of lubricant to the LM rail raceway.

This allows an oil film to be constantly formed between the rollers and the raceway and significantly extends the lubrication maintenance interval.

The QZ Lubricator is made primarily of three components:

- (1) a highly oil-impregnated fiber net (which stores lubricant),
- (2) a high-density fiber net (which applies the lubricant to the raceways), and
- (3) an oil control plate (which adjusts the amount of oil being applied).

The lubricant is supplied from within the QZ Lubricator using the basic principle of capillary action, as used in felt-tip pens.

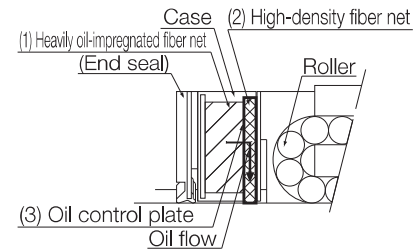

Structural Drawing

Features

- Since it compensates for oil loss, the lubrication maintenance interval can be significantly extended.
- It is an eco-friendly lubrication system that does not contaminate the surrounding area, as it feeds the right amount of lubricant to the roller raceway.

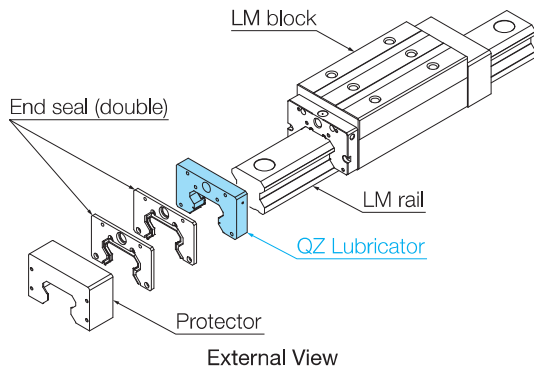

External View

| Symbol | Contamination protection accessories |
|--------|----------------------------------------------------------------------|
| QZUU | End seals + QZ |
| QZSS | End seals + side seals + inner seals + QZ |
| QZDD | Double seals + side seals + inner seals + QZ |
| QZZZ | End seals + side seals + inner seals + metal scrapers + QZ |
| QZKK | Double seals + side seals + inner seals + metal scrapers + QZ |
| QZSSH | End seals + side seals + inner seals + LaCS + QZ |
| QZDDH | Double seals + side seals + inner seals + LaCS + QZ |
| QZZZH | End seals + side seals + inner seals + LaCS + metal scrapers + QZ |
| QZKHH | Double seals + side seals + inner seals + LaCS + metal scrapers + QZ |
| QZJHH | End seals + side seals + inner seals + LaCS + protectors + QZ |
| QZTTH | Double seals + side seals + inner seals + LaCS + protectors + QZ |

The Overall LM Block Length Dimension with QZ Lubricator and Seals Attached

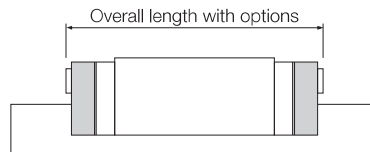

Unit: mm

| Symbol | Overall length when options are attached | | | | | | | | | | | |
|-----------|------------------------------------------|--------|-------|--------|-------|--------|-------|--------|-------|--------|-------|--------|
| | HRX25 | HRX25L | HRX30 | HRX30L | HRX35 | HRX35L | HRX45 | HRX45L | HRX55 | HRX55L | HRX65 | HRX65L |
| QZUU/QZSS | 129.6 | 146.4 | 140.6 | 165.1 | 153.2 | 181.2 | 180.7 | 215.7 | 220.2 | 269.7 | 279.1 | 344.1 |
| QZDD | 134.8 | 151.6 | 147.2 | 171.7 | 160.2 | 188.2 | 187.7 | 222.7 | 227.2 | 276.7 | 286.5 | 351.5 |
| QZZZ | 134.6 | 151.4 | 145.6 | 170.1 | 161.6 | 189.6 | 189.9 | 224.9 | 229.4 | 278.9 | 290.3 | 355.3 |
| QZKK | 139.8 | 156.6 | 152.2 | 176.7 | 168.6 | 196.6 | 196.9 | 231.9 | 236.4 | 285.9 | 297.7 | 362.7 |
| QZSSH | 147.2 | 164 | 158.2 | 182.7 | 170.8 | 198.8 | 201.3 | 236.3 | 240.8 | 290.3 | 303.1 | 368.1 |
| QZDDH | 152.4 | 169.2 | 164.8 | 189.3 | 177.8 | 205.8 | 208.3 | 243.3 | 247.8 | 297.3 | 310.5 | 375.5 |
| QZZZH | 152.2 | 169 | 163.2 | 187.7 | 179.2 | 207.2 | 210.5 | 245.5 | 250 | 299.5 | 314.3 | 379.3 |
| QZKHH | 157.4 | 174.2 | 169.8 | 194.3 | 186.2 | 214.2 | 217.5 | 252.5 | 257 | 306.5 | 321.7 | 386.7 |
| QZJHH | 152.2 | 169 | 163.2 | 187.7 | 179.2 | 207.2 | 210.3 | 245.3 | 249.8 | 299.3 | 314.1 | 379.1 |

Radial Clearance Specifications

The Model HRX has one type of radial clearance (preload).

Medium preload (C0)

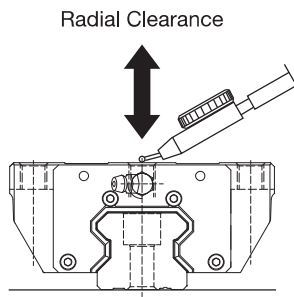

Radial Clearance Specifications Unit: μm

| Applicable model | Medium preload (C0) |
|------------------|---------------------|
| HRX25 | -2 to -1 |
| HRX30 | -2 to -1 |
| HRX35 | -2 to -1 |
| HRX45 | -3 to -2 |
| HRX55 | -3 to -2 |
| HRX65 | -4 to -2 |

Accuracy Standards

The accuracy of the LM Guide is specified for each model in terms of the dimensional tolerance for height and width, the difference between height and width in a pair, and running parallelism. (High accuracy grade/Precision grade)

Difference in Height (M)

Indicates the difference between the minimum and maximum values of height (M) of each LM Guide used on the same plane in combination.

Difference in Width (W_2)

Indicates a difference between the minimum and maximum values of the width (W_2) between each of the LM blocks, mounted on one LM rail in combination, and the LM rail.

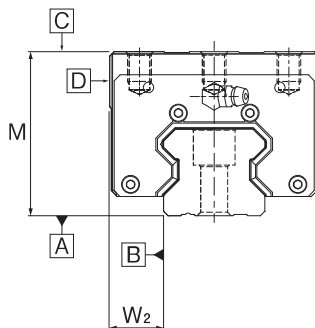

Accuracy Standards Unit: mm

| Model No. | Accuracy (symbol) | High accuracy grade (H) | Precision grade (P) |
|----------------|----------------------------------------------------|-------------------------------------------------------------------------------------|------------------------------------------|
| | Item | | |
| 25 30 35 | Dimensional tolerance in height (M) | ± 0.04 | $\begin{matrix} 0 \\ -0.04 \end{matrix}$ |
| | Difference in height (M) | 0.015 | 0.007 |
| | Dimensional tolerance in width (W_2) | ± 0.03 | $\begin{matrix} 0 \\ -0.03 \end{matrix}$ |
| | Difference in width (W_2) | 0.015 | 0.007 |
| | Running parallelism of surface C against surface A | See the table below for LM rail length and running parallelism by accuracy standard | |
| | Running parallelism of surface D against surface B | See the table below for LM rail length and running parallelism by accuracy standard | |
| 45 55 | Dimensional tolerance in height (M) | ± 0.04 | $\begin{matrix} 0 \\ -0.05 \end{matrix}$ |
| | Difference in height (M) | 0.015 | 0.007 |
| | Dimensional tolerance in width (W_2) | ± 0.04 | $\begin{matrix} 0 \\ -0.04 \end{matrix}$ |
| | Difference in width (W_2) | 0.015 | 0.007 |
| | Running parallelism of surface C against surface A | See the table below for LM rail length and running parallelism by accuracy standard | |
| | Running parallelism of surface D against surface B | See the table below for LM rail length and running parallelism by accuracy standard | |
| 65 | Dimensional tolerance in height (M) | ± 0.04 | $\begin{matrix} 0 \\ -0.05 \end{matrix}$ |
| | Difference in height (M) | 0.02 | 0.01 |
| | Dimensional tolerance in width (W_2) | ± 0.04 | $\begin{matrix} 0 \\ -0.05 \end{matrix}$ |
| | Difference in width (W_2) | 0.02 | 0.01 |
| | Running parallelism of surface C against surface A | See the table below for LM rail length and running parallelism by accuracy standard | |
| | Running parallelism of surface D against surface B | See the table below for LM rail length and running parallelism by accuracy standard | |

Running Parallelism

Refers to the tolerance for parallelism between the LM block and the LM rail datum surface when the LM block travels the whole length of the LM rail bolted to a reference surface.

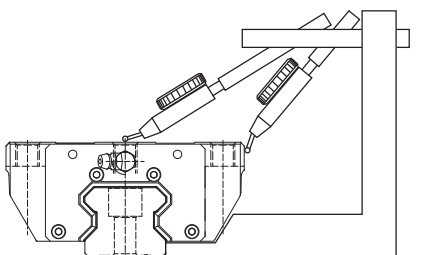

LM Rail Length and Running Parallelism by Accuracy Standard Unit: μm

| Rail length (mm) | | Running parallelism values | |
|------------------|---------|----------------------------|---------------------|
| Above | Or less | High accuracy grade (H) | Precision grade (P) |
| — | 50 | 3 | 2 |
| 50 | 80 | 3 | 2 |
| 80 | 125 | 3 | 2 |
| 125 | 200 | 3,5 | 2 |
| 200 | 250 | 4 | 2,5 |
| 250 | 315 | 4,5 | 3 |
| 315 | 400 | 5 | 3,5 |
| 400 | 500 | 6 | 4,5 |
| 500 | 630 | 7 | 5 |
| 630 | 800 | 8,5 | 6 |
| 800 | 1000 | 9 | 6,5 |
| 1000 | 1250 | 11 | 7,5 |
| 1250 | 1600 | 12 | 8 |
| 1600 | 2000 | 13 | 8,5 |
| 2000 | 2500 | 14 | 9,5 |
| 2500 | 3090 | 16 | 11 |

Standard and Maximum Lengths of the LM Rail

The standard and maximum lengths of Model HRX LM rails are shown in the following table. If the maximum length of the desired LM rail exceeds these values, joint rails will be used. Contact THK for details.

For special rail lengths, it is recommended to use a value corresponding to the G, g dimensions from the table. As the G, g dimensions increase, that portion becomes less stable, and the accuracy may be negatively affected.

*If joint rails are not allowed, and a length greater than the maximum values is required, contact THK.

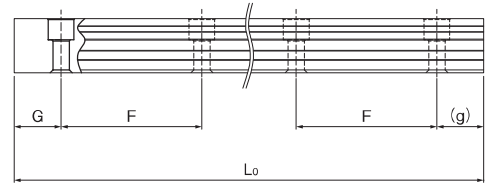

Standard Length and Maximum Length of the LM Rail

Unit: mm

| Model No. | HRX25 | HRX30, 35 | HRX45 | HRX55 | HRX65 |
|-------------------------------------------|-------|-----------|-------|-------|-------|
| LM rail standard length (L ₀) | 220 | 280 | 570 | 780 | 1270 |
| | 280 | 360 | 675 | 900 | 1570 |
| | 340 | 440 | 780 | 1020 | 2020 |
| | 400 | 520 | 885 | 1140 | 2620 |
| | 460 | 600 | 990 | 1260 | — |
| | 520 | 680 | 1095 | 1380 | — |
| | 580 | 760 | 1200 | 1500 | — |
| | 640 | 840 | 1305 | 1620 | — |
| | 700 | 920 | 1410 | 1740 | — |
| | 760 | 1000 | 1515 | 1860 | — |
| | 820 | 1080 | 1620 | 1980 | — |
| | 940 | 1160 | 1725 | 2100 | — |
| | 1000 | 1240 | 1830 | 2220 | — |
| | 1060 | 1320 | 1935 | 2340 | — |
| | 1120 | 1400 | 2040 | 2460 | — |
| | 1180 | 1480 | 2145 | 2580 | — |
| 1240 | 1560 | 2250 | 2700 | — | |

| Model No. | HRX25 | HRX30, 35 | HRX45 | HRX55 | HRX65 |
|-------------------------------------------|-------|-----------|-------|-------|-------|
| LM rail standard length (L ₀) | 1300 | 1640 | 2355 | 2820 | — |
| | 1360 | 1720 | 2460 | 2940 | — |
| | 1420 | 1800 | 2565 | 3060 | — |
| | 1480 | 1880 | 2670 | — | — |
| | 1540 | 1960 | 2775 | — | — |
| | 1600 | 2040 | 2880 | — | — |
| | 1720 | 2200 | 2985 | — | — |
| | 1840 | 2360 | 3090 | — | — |
| | 1960 | 2520 | — | — | — |
| | 2080 | 2680 | — | — | — |
| | 2200 | 2840 | — | — | — |
| | 2320 | 3000 | — | — | — |
| | 2440 | — | — | — | — |
| Standard pitch | 60 | 80 | 105 | 120 | 150 |
| G, g | 20 | 20 | 22.5 | 30 | 35 |
| Maximum length | 3000 | 3000 | 3090 | 3060 | 3000 |

Shoulder Height of the Mounting Base and the Corner Radius

The mounting base for the LM rail and LM block has a reference surface on the side face to allow easy installation. The height of the datum shoulder varies based on the model. See below for details. The corner of the mounting shoulder must be machined to have a recess, or machined to be smaller than the corner radius (r), to prevent interference with the chamfer of the LM rail or the LM block. The corner radius (r) varies based on the model. See below for details.

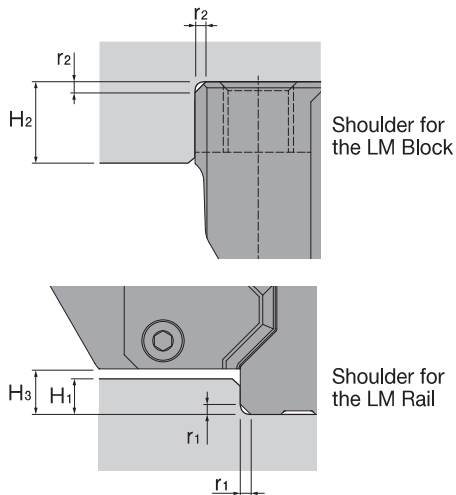

Shoulder Height of the Mounting Base and the Corner Radius

Unit: mm

| Model No. | Corner radius (LM rail) r ₁ (max) | Corner radius (LM block) r ₂ (max) | Shoulder height (LM rail) H ₁ (max) | Shoulder height (LM block) H ₂ (max) | H ₃ |
|-----------|----------------------------------------------|-----------------------------------------------|------------------------------------------------|-------------------------------------------------|----------------|
| HRX25 | 1.0 | 1.0 | 4.0 | 5.0 | 5.0 |
| HRX30 | 1.0 | 1.0 | 4.0 | 5.0 | 5.0 |
| HRX35 | 1.0 | 1.0 | 5.5 | 6.0 | 6.5 |
| HRX45 | 1.5 | 1.5 | 6.5 | 8.0 | 8.5 |
| HRX55 | 1.5 | 1.5 | 9.0 | 10.0 | 11 |
| HRX65 | 1.5 | 2.0 | 9.5 | 10.0 | 12 |

Error Allowance in the Mounting Surface

■ Error Allowance in Parallelism Between Two Rails

Misalignment of the mounting surface can impact the product life of an LM Guide. The table below shows the approximate value (P) of the error allowance in parallelism between two rails under normal use for each model number.

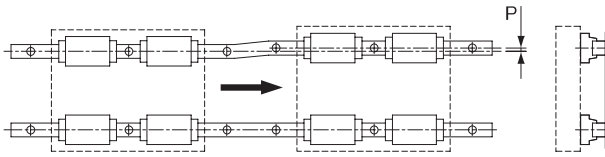

Unit: μm

| Model No. | Medium preload (C0 clearance) |
|-----------|-------------------------------|
| HRX25 | 7 |
| HRX30 | 8 |
| HRX35 | 9 |
| HRX45 | 11 |
| HRX55 | 13 |
| HRX65 | 17 |

■ Error Allowance in Vertical Level Between Two Rails

The table below shows the value (S) of the error allowance in the vertical level between two rails spaced 500 mm apart, which is proportional to the distance between the rails.

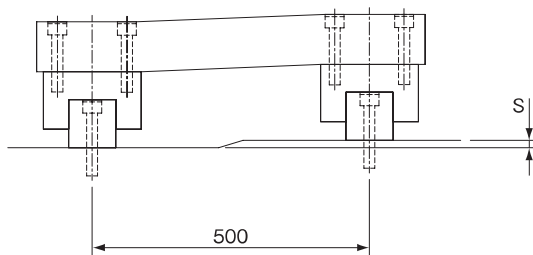

Unit: μm

| Model No. | Medium preload (C0 clearance) |
|-----------|-------------------------------|
| HRX25 | 70 |
| HRX30 | |
| HRX35 | |
| HRX45 | |
| HRX55 | |
| HRX65 | |

■ Error Allowance in Level in the Axial Direction

The table below shows the value (Y) of the error allowance in vertical level of the block span (b), which is proportional to the block span (b).

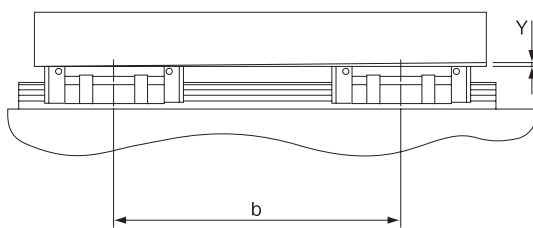

Unit: mm

| | |
|---------------------------------------------|------------|
| Error allowance in the mounting surface (Y) | $0.00004b$ |
|---------------------------------------------|------------|

Specification Table

HRX-C/LC

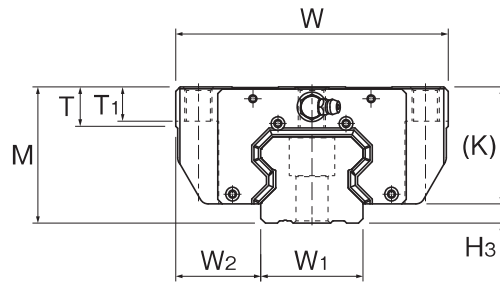

| Model No. | External dimensions | | | | | | | Block dimensions | | | | | | | | Pilot hole for side nipple | | | Greasing hole on the top face | | | | |
|-----------|---------------------|----|-----|-------|-----|----------------|----|------------------|----------------|-------|----------------|----|------|------|---------------|----------------------------|----------------|----------------|-------------------------------|------|----------------|----------------|---|
| | M | W | L | B | C | C ₂ | S | H | L ₁ | T | T ₁ | K | N | E | Grease nipple | e ₀ | f ₀ | D ₀ | D ₂ (O-ring) | V | e ₁ | d ₂ | |
| HRX25 | C | 36 | 70 | 99.6 | 57 | 45 | 40 | M8 through | 6.8 | 75.4 | 9.5 | 10 | 31 | 5.5 | 12 | B-M6F | 6 | 6.2 | 5.2 | 6.2 | 0.3 | 4.5 | 1 |
| | LC | 36 | 70 | 116.4 | 57 | 45 | 40 | M8 through | 6.8 | 92.2 | 9.5 | 10 | 31 | 5.5 | 12 | B-M6F | 6 | 6.2 | 5.2 | 6.2 | 0.3 | 4.5 | 1 |
| HRX30 | C | 42 | 90 | 110.6 | 72 | 52 | 44 | M10 through | 8.5 | 84.0 | 12 | 14 | 37 | 8.2 | 12 | B-M6F | 6.2 | 9.5 | 5.2 | 6.2 | 0.4 | 4.5 | 1 |
| | LC | 42 | 90 | 135.1 | 72 | 52 | 44 | M10 through | 8.5 | 108.5 | 12 | 14 | 37 | 8.2 | 12 | B-M6F | 6.2 | 9.5 | 5.2 | 6.2 | 0.4 | 4.5 | 1 |
| HRX35 | C | 48 | 100 | 123.2 | 82 | 62 | 52 | M10 through | 8.5 | 92.2 | 12 | 10 | 41.5 | 8 | 12 | B-M6F | 7.2 | 9.5 | 5.2 | 10.2 | 0.45 | 5.8 | 1 |
| | LC | 48 | 100 | 151.2 | 82 | 62 | 52 | M10 through | 8.5 | 120.2 | 12 | 10 | 41.5 | 8 | 12 | B-M6F | 7.2 | 9.5 | 5.2 | 10.2 | 0.45 | 5.8 | 1 |
| HRX45 | C | 60 | 120 | 150.7 | 100 | 80 | 60 | M12 through | 10.5 | 115.7 | 17.3 | 15 | 51.5 | 8.75 | 16 | B-PT1/8 | 7.5 | 7.75 | 5.2 | 10.2 | 0.45 | 6.9 | 1 |
| | LC | 60 | 120 | 185.7 | 100 | 80 | 60 | M12 through | 10.5 | 150.7 | 17.3 | 15 | 51.5 | 8.75 | 16 | B-PT1/8 | 7.5 | 7.75 | 5.2 | 10.2 | 0.45 | 6.9 | 1 |
| HRX55 | C | 70 | 140 | 180.2 | 116 | 95 | 70 | M14 through | 12.5 | 143.2 | 18.2 | 18 | 59 | 11.2 | 16 | B-PT1/8 | 6.8 | 9.3 | 5.2 | 10.2 | 0.45 | 6.8 | 1 |
| | LC | 70 | 140 | 229.7 | 116 | 95 | 70 | M14 through | 12.5 | 192.7 | 18.2 | 18 | 59 | 11.2 | 16 | B-PT1/8 | 6.8 | 9.3 | 5.2 | 10.2 | 0.45 | 6.8 | 1 |
| HRX65 | C | 90 | 170 | 239.1 | 142 | 110 | 82 | M16 through | 14.5 | 195.7 | 22.3 | 20 | 78 | 18 | 16 | B-PT1/8 | 8.65 | 16.6 | 5.2 | 10.2 | 0.45 | 8.65 | 1 |
| | LC | 90 | 170 | 304.1 | 142 | 110 | 82 | M16 through | 14.5 | 260.7 | 22.3 | 20 | 78 | 18 | 16 | B-PT1/8 | 8.65 | 16.6 | 5.2 | 10.2 | 0.45 | 8.65 | 1 |

Model Number Coding

Select an option (orange box) Fixed symbol (grey box)

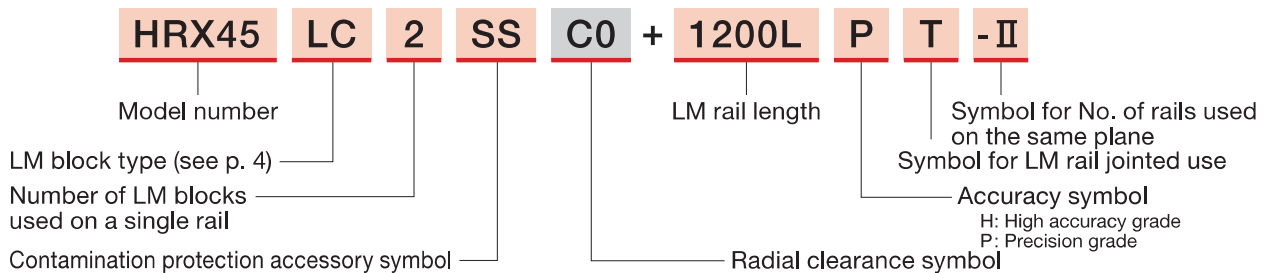

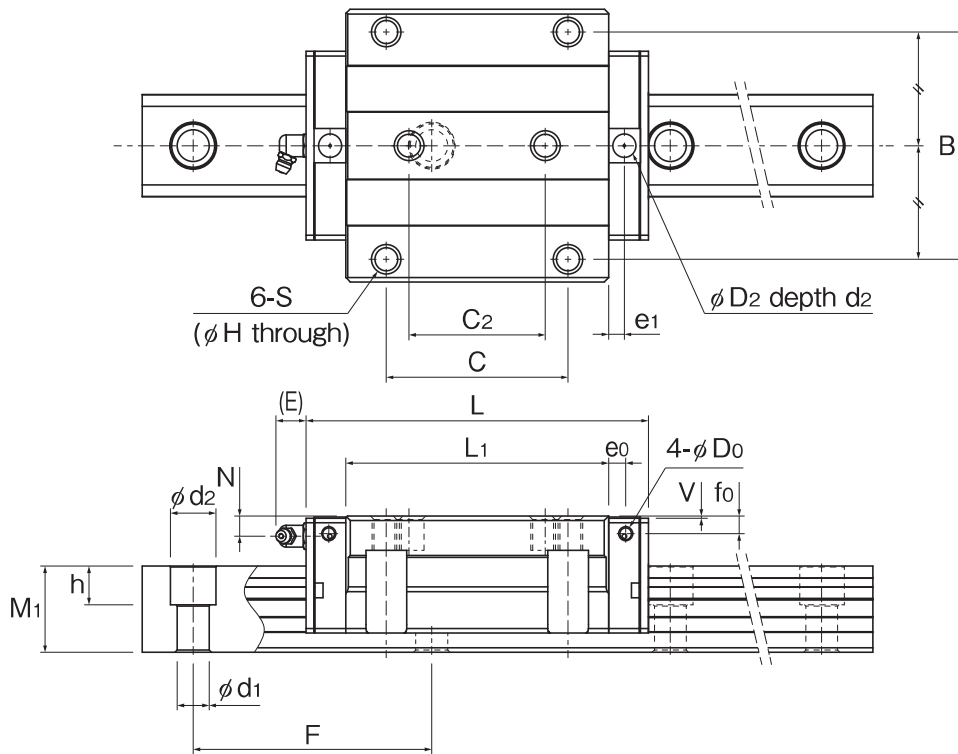

Unit: mm

| H_3 | Rail dimensions | | | | | Basic load rating (kN) | | Static permissible moment (kN·m)* | | | | Weight | | |
|-------|---------------------|-------|-------|-----|---------------------------|------------------------|-------|-----------------------------------|----------|---------|----------|--------|------------------|-------------------|
| | W_1 0 -0.05 | W_2 | M_1 | F | $d_1 \times d_2 \times h$ | C_{100} | C_0 | M_A | | M_B | | M_C | LM block (kg) | LM rail (kg/m) |
| | | | | | | | | 1 block | 2 blocks | 1 block | 2 blocks | | | |
| 5 | 23 | 23.5 | 21.5 | 60 | 7×11×9 | 26.3 | 73.1 | 0.92 | 4.84 | 0.92 | 4.84 | 0.57 | 0.84 | 3.25 |
| 5 | 23 | 23.5 | 21.5 | 60 | 7×11×9 | 30.8 | 89.3 | 1.37 | 6.86 | 1.37 | 6.86 | 0.69 | 1.03 | 3.25 |
| 5 | 28 | 31 | 23.5 | 80 | 9×14×12 | 39.4 | 104.7 | 1.48 | 7.72 | 1.48 | 7.72 | 1.03 | 1.48 | 4.42 |
| 5 | 28 | 31 | 23.5 | 80 | 9×14×12 | 48.0 | 135.2 | 2.44 | 12.06 | 2.44 | 12.06 | 1.33 | 1.93 | 4.42 |
| 6.5 | 34 | 33 | 29 | 80 | 9×14×12 | 56.0 | 150.1 | 2.33 | 11.59 | 2.33 | 11.59 | 1.81 | 1.93 | 6.33 |
| 6.5 | 34 | 33 | 29 | 80 | 9×14×12 | 68.9 | 195.7 | 3.92 | 18.60 | 3.92 | 18.60 | 2.36 | 2.55 | 6.33 |
| 8.5 | 45 | 37.5 | 38 | 105 | 14×20×17 | 94.3 | 250.4 | 4.85 | 23.90 | 4.85 | 23.90 | 3.84 | 3.51 | 10.9 |
| 8.5 | 45 | 37.5 | 38 | 105 | 14×20×17 | 116.0 | 326.7 | 8.17 | 38.44 | 8.17 | 38.44 | 5.01 | 4.64 | 10.9 |
| 11 | 53 | 43.5 | 44 | 120 | 16×23×20 | 134.5 | 369.9 | 8.86 | 42.34 | 8.86 | 42.34 | 6.86 | 5.85 | 15.6 |
| 11 | 53 | 43.5 | 44 | 120 | 16×23×20 | 169.5 | 497.9 | 15.86 | 72.70 | 15.86 | 72.70 | 9.24 | 7.96 | 15.6 |
| 12 | 63 | 53.5 | 53 | 150 | 18×26×22 | 205.5 | 567.0 | 18.43 | 86.49 | 18.43 | 86.49 | 12.27 | 13.34 | 22.6 |
| 12 | 63 | 53.5 | 53 | 150 | 18×26×22 | 257.0 | 756.0 | 32.04 | 146.69 | 32.04 | 146.69 | 16.35 | 17.94 | 22.6 |

*Static permissible moment 1 block: static permissible moment value with 1 LM block
2 blocks: static permissible moment value with 2 blocks in close contact with each other

Specification Table

HRX-R/LR

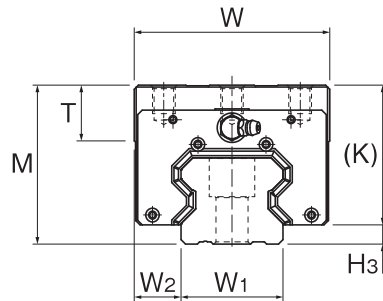

| Model No. | | External dimensions | | | | | Block dimensions | | | | | | Pilot hole for side nipple | | | Greasing hole on the top face | | | | |
|-----------|----|---------------------|-----|-------|----|-----|------------------|----------------|------|------|-------|----|----------------------------|----------------|----------------|-------------------------------|-------------------------|-------|----------------|----------------|
| | | M | W | L | B | C | S×ℓ | L ₁ | T | K | N | E | Grease nipple | e ₀ | f ₀ | D ₀ | D ₂ (O-ring) | V | e ₁ | d ₂ |
| HRX25 | R | 40 | 48 | 99.6 | 35 | 35 | M6×7 | 75.4 | 9 | 35 | 9.5 | 12 | B-M6F | 6 | 10.2 | 5.2 | 6.2 | 4.3 | 4.5 | 1 |
| | LR | 40 | 48 | 116.4 | 35 | 50 | M6×7 | 92.2 | 9 | 35 | 9.5 | 12 | B-M6F | 6 | 10.2 | 5.2 | 6.2 | 4.3 | 4.5 | 1 |
| HRX30 | R | 45 | 60 | 110.6 | 40 | 40 | M8×8 | 84.0 | 12 | 40 | 11.2 | 12 | B-M6F | 6.2 | 12.5 | 5.2 | 6.2 | 3.4 | 4.5 | 1 |
| | LR | 45 | 60 | 135.1 | 40 | 60 | M8×8 | 108.5 | 12 | 40 | 11.2 | 12 | B-M6F | 6.2 | 12.5 | 5.2 | 6.2 | 3.4 | 4.5 | 1 |
| HRX35 | R | 55 | 70 | 123.2 | 50 | 50 | M8×10 | 92.2 | 18.5 | 48.5 | 15 | 12 | B-M6F | 7.2 | 16.5 | 5.2 | 10.2 | 7.45 | 5.8 | 1 |
| | LR | 55 | 70 | 151.2 | 50 | 72 | M8×10 | 120.2 | 18.5 | 48.5 | 15 | 12 | B-M6F | 7.2 | 16.5 | 5.2 | 10.2 | 7.45 | 5.8 | 1 |
| HRX45 | R | 70 | 86 | 150.7 | 60 | 60 | M10×12.5 | 115.7 | 24.5 | 61.5 | 18.75 | 16 | B-PT1/8 | 7.5 | 17.75 | 5.2 | 10.2 | 10.45 | 6.9 | 1 |
| | LR | 70 | 86 | 185.7 | 60 | 80 | M10×12.5 | 150.7 | 24.5 | 61.5 | 18.75 | 16 | B-PT1/8 | 7.5 | 17.75 | 5.2 | 10.2 | 10.45 | 6.9 | 1 |
| HRX55 | R | 80 | 100 | 180.2 | 75 | 75 | M12×15 | 143.2 | 27.5 | 69 | 21.2 | 16 | B-PT1/8 | 6.8 | 19.3 | 5.2 | 10.2 | 10.45 | 6.8 | 1 |
| | LR | 80 | 100 | 229.7 | 75 | 95 | M12×15 | 192.7 | 27.5 | 69 | 21.2 | 16 | B-PT1/8 | 6.8 | 19.3 | 5.2 | 10.2 | 10.45 | 6.8 | 1 |
| HRX65 | R | 100 | 126 | 239.1 | 76 | 70 | M16×20 | 195.7 | 29.5 | 88 | 28 | 16 | B-PT1/8 | 8.65 | 26.6 | 5.2 | 10.2 | 10.45 | 8.65 | 1 |
| | LR | 100 | 126 | 304.1 | 76 | 120 | M16×20 | 260.7 | 29.5 | 88 | 28 | 16 | B-PT1/8 | 8.65 | 26.6 | 5.2 | 10.2 | 10.45 | 8.65 | 1 |

Model Number Coding

Select an option (orange box) Fixed symbol (grey box)

HRX45 **LR** **2** **SS** **C0** + **1200L** **P** **T** **-II**

Model number

LM block type (see p. 4)

Number of LM blocks used on a single rail

Contamination protection accessory symbol

LM rail length

Radial clearance symbol

Symbol for No. of rails used on the same plane

Symbol for LM rail jointed use

Accuracy symbol
H: High accuracy grade
P: Precision grade

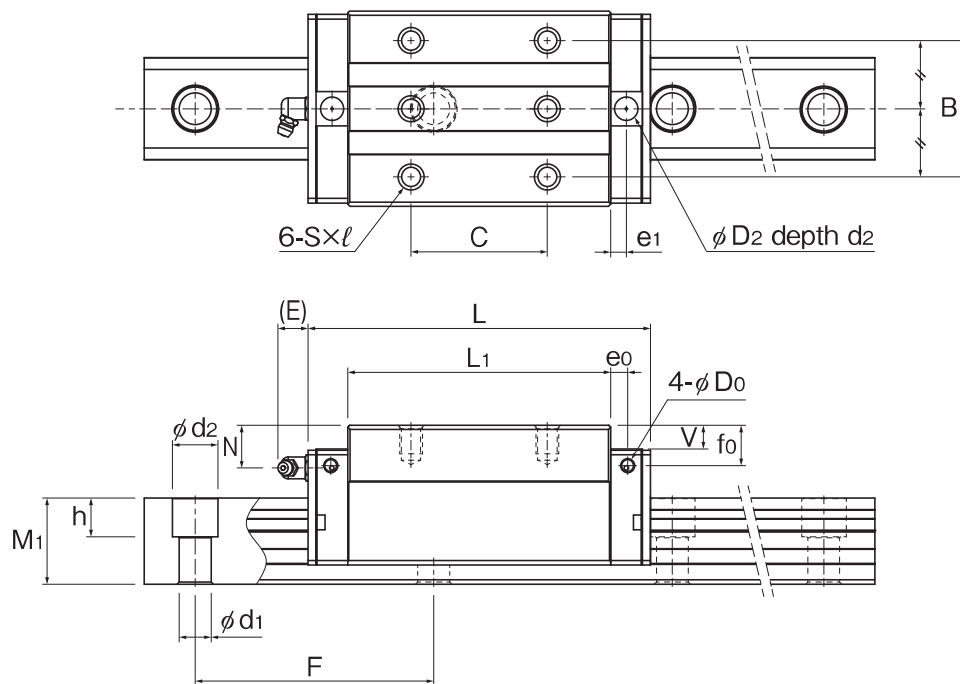

Unit: mm

| H_3 | Rail dimensions | | | | | Basic load rating (kN) | | Static permissible moment (kN·m)* | | | | Weight | | |
|-------|---------------------|-------|-------|-----|---------------------------|------------------------|-------|-----------------------------------|----------|---------|----------|--------|------------------|-------------------|
| | W_1 0 -0.05 | W_2 | M_1 | F | $d_1 \times d_2 \times h$ | C_{100} | C_0 | M_A | | M_B | | M_C | LM block (kg) | LM rail (kg/m) |
| | | | | | | | | 1 block | 2 blocks | 1 block | 2 blocks | | | |
| 5 | 23 | 12,5 | 21,5 | 60 | 7×11×9 | 26,3 | 73,1 | 0,92 | 4,84 | 0,92 | 4,84 | 0,57 | 0,72 | 3,25 |
| 5 | 23 | 12,5 | 21,5 | 60 | 7×11×9 | 30,8 | 89,3 | 1,37 | 6,86 | 1,37 | 6,86 | 0,69 | 0,86 | 3,25 |
| 5 | 28 | 16 | 23,5 | 80 | 9×14×12 | 39,4 | 104,7 | 1,48 | 7,72 | 1,48 | 7,72 | 1,03 | 1,16 | 4,42 |
| 5 | 28 | 16 | 23,5 | 80 | 9×14×12 | 48,0 | 135,2 | 2,44 | 12,06 | 2,44 | 12,06 | 1,33 | 1,48 | 4,42 |
| 6,5 | 34 | 18 | 29 | 80 | 9×14×12 | 56,0 | 150,1 | 2,33 | 11,59 | 2,33 | 11,59 | 1,81 | 1,73 | 6,33 |
| 6,5 | 34 | 18 | 29 | 80 | 9×14×12 | 68,9 | 195,7 | 3,92 | 18,60 | 3,92 | 18,60 | 2,36 | 2,23 | 6,33 |
| 8,5 | 45 | 20,5 | 38 | 105 | 14×20×17 | 94,3 | 250,4 | 4,85 | 23,90 | 4,85 | 23,90 | 3,84 | 3,20 | 10,9 |
| 8,5 | 45 | 20,5 | 38 | 105 | 14×20×17 | 116,0 | 326,7 | 8,17 | 38,44 | 8,17 | 38,44 | 5,01 | 4,15 | 10,9 |
| 11 | 53 | 23,5 | 44 | 120 | 16×23×20 | 134,5 | 369,9 | 8,86 | 42,34 | 8,86 | 42,34 | 6,86 | 5,31 | 15,6 |
| 11 | 53 | 23,5 | 44 | 120 | 16×23×20 | 169,5 | 497,9 | 15,86 | 72,70 | 15,86 | 72,70 | 9,24 | 7,12 | 15,6 |
| 12 | 63 | 31,5 | 53 | 150 | 18×26×22 | 205,5 | 567,0 | 18,43 | 86,49 | 18,43 | 86,49 | 12,27 | 12,06 | 22,6 |
| 12 | 63 | 31,5 | 53 | 150 | 18×26×22 | 257,0 | 756,0 | 32,04 | 146,69 | 32,04 | 146,69 | 16,35 | 16,01 | 22,6 |

*Static permissible moment 1 block: static permissible moment value with 1 LM block
2 blocks: static permissible moment value with 2 blocks in close contact with each other

Feature 3 LM Blocks and LM Rails Available for Individual Sale

HRX-GK

LM blocks and LM rails available for individual sale

Flexible combinations, simple, quick

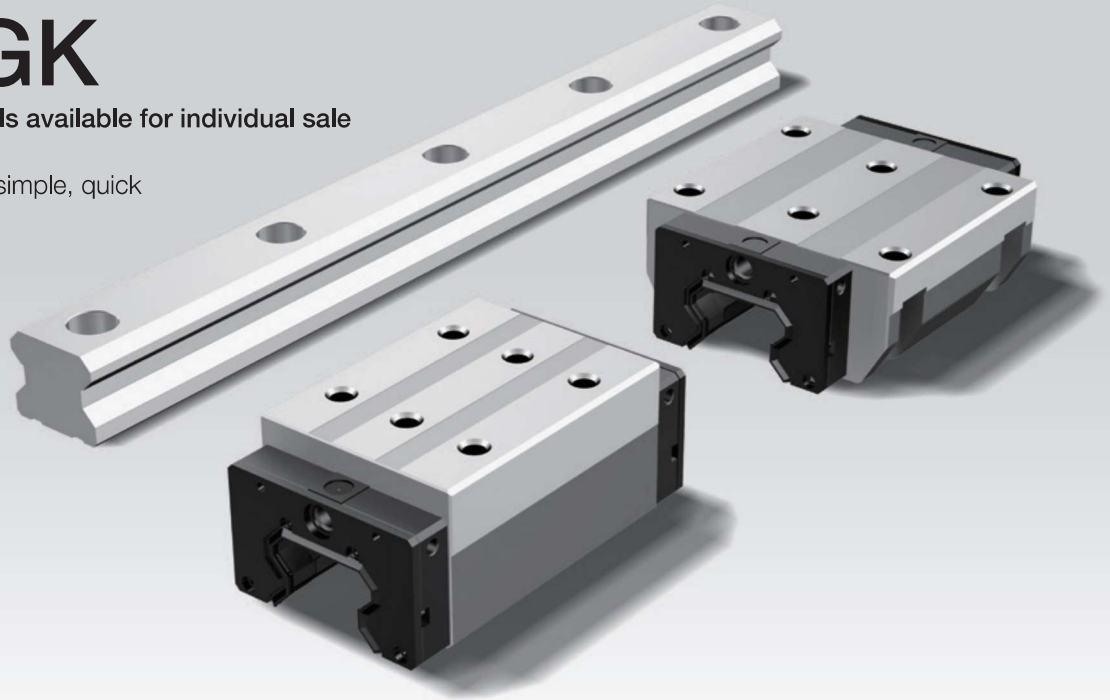

Lineup

| Block type | | HRX25 | HRX30 | HRX35 | HRX45 |
|---------------|----|-------|-------|-------|-------|
| Standard type | R | ○ | ○ | ○ | ○ |
| | C | ○ | ○ | ○ | ○ |
| Long type | LR | ○ | ○ | ○ | ○ |
| | LC | ○ | ○ | ○ | ○ |

Please contact THK about HRX55 and HRX65.

Model Number Coding

LM Rail

Select an option (orange box) Fixed symbol (grey box)

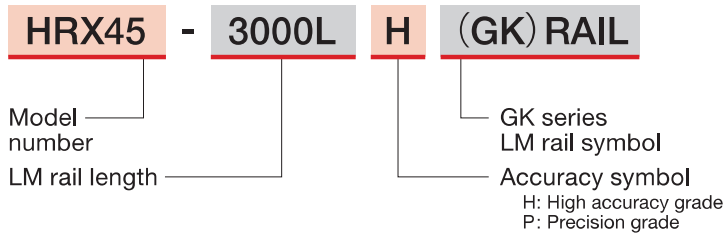

LM Block

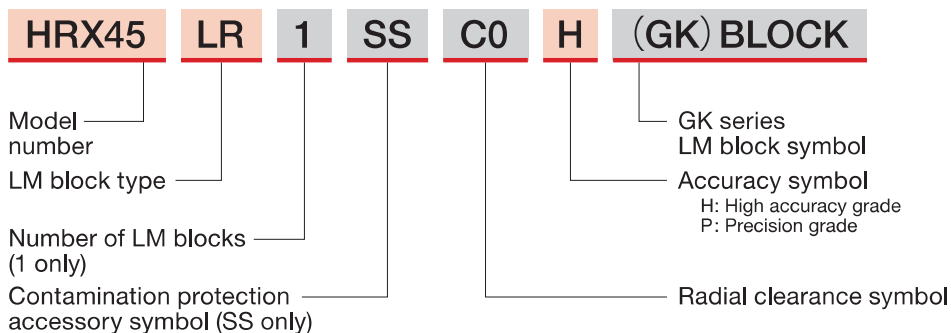

Accuracy Standards

The accuracy of the LM Guide is specified for each model in terms of the dimensional tolerance for height and width, the difference between height and width in a pair, and running parallelism. (High accuracy grade/Precision grade)

Difference in Height (M)

Indicates the difference between the minimum and maximum values of height (M) of each LM Guide used on the same plane in combination.

Difference in Width (W₂)

Indicates a difference between the minimum and maximum values of the width (W₂) between each of the LM blocks, mounted on one LM rail in combination, and the LM rail.

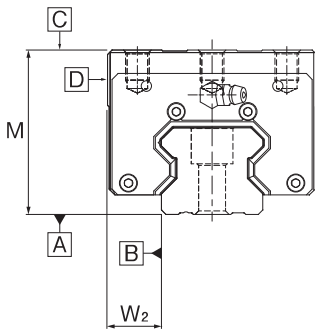

Accuracy standards

Unit: mm

| Model No. | Accuracy (symbol) | | High accuracy grade (H) | Precision grade (P) |
|----------------|----------------------------------------------------|---------------------------------------------------|----------------------------------------------------------------------------------------|---------------------|
| | Item | | | |
| 25 30 35 | Dimensional tolerance in height (M) | | ±0.04 | 0 -0,04 |
| | Difference in height (M) dimension | Multiple blocks on a single rail (1 set) | 0.015 | 0.007 |
| | | Multiple blocks on multiple rails (Multiple sets) | 0.03 | 0.025 |
| | Dimensional tolerance in width (W ₂) | | ±0.03 | 0 -0,03 |
| | Difference in width (W ₂) | | 0.015 | 0.007 |
| | Running parallelism of surface C against surface A | | See the table on p. 8 for LM rail length and running parallelism by accuracy standard. | |
| | Running parallelism of surface D against surface B | | See the table on p. 8 for LM rail length and running parallelism by accuracy standard. | |
| 45 | Dimensional tolerance in height (M) | | ±0.04 | 0 -0,05 |
| | Difference in height (M) dimension | Multiple blocks on a single rail (1 set) | 0.015 | 0.007 |
| | | Multiple blocks on multiple rails (Multiple sets) | 0.03 | 0.025 |
| | Dimensional tolerance in width (W ₂) | | ±0.04 | 0 -0,04 |
| | Difference in width (W ₂) | | 0.015 | 0.007 |
| | Running parallelism of surface C against surface A | | See the table on p. 8 for LM rail length and running parallelism by accuracy standard. | |
| | Running parallelism of surface D against surface B | | See the table on p. 8 for LM rail length and running parallelism by accuracy standard. | |

Please contact THK about HRX55 and HRX65.

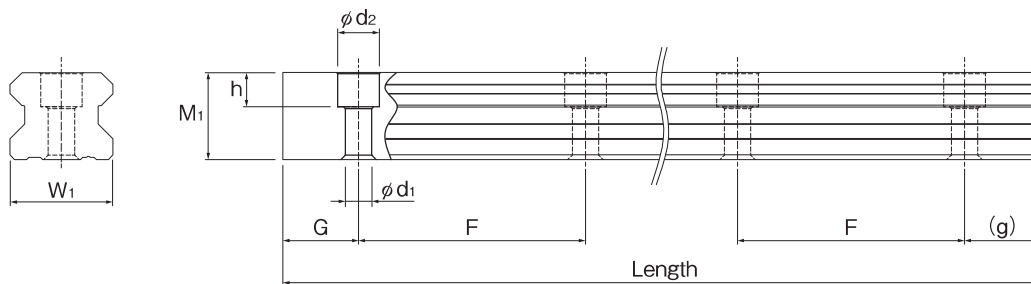

LM Rail Dimensions

Unit: mm

| Model No. | Rail dimensions | | | | | Weight |
|-----------|-----------------|----------------|-----|-----------------------------------|---------------|----------------|
| | W ₁ | M ₁ | F | d ₁ ×d ₂ ×h | Length (G, g) | LM rail (kg/m) |
| HRX25 | 23 | 21,5 | 60 | 7×11×9 | 3000 (20, 40) | 3,25 |
| HRX30 | 28 | 23,5 | 80 | 9×14×12 | 3000 (20, 20) | 4,42 |
| HRX35 | 34 | 29 | 80 | 9×14×12 | 3000 (20, 20) | 6,33 |
| HRX45 | 45 | 38 | 105 | 14×20×17 | 3000 (20, 40) | 10,9 |

HRX, HRX (GK) Calculating the Static Safety Factor, Nominal Life, and Service Life Time

Static Safety Factor

To calculate a load applied to the LM Guide, you must first obtain the average load required to determine the service life and the maximum load needed to determine the static safety factor. In particular, if the system starts and stops frequently, if a cutting load acts on the system, or if a large moment caused by an overhanging load is applied, it may experience an unexpectedly large load. When selecting a model number, make sure that the desired model is capable of supporting the required maximum load (whether stationary or in motion).

The reference values for the static safety factor are shown in the table to the right.

Reference Values for the Static Safety Factor (f_s)

| Machine | Load conditions | Lower limit of f_s |
|------------------------------|-------------------------------|----------------------|
| General industrial machinery | Without vibrations or impacts | 3.0 to 6.0 |
| | With vibrations or impacts | 4.0 to 7.0 |
| Machine tools | Without vibrations or impacts | 3.0 to 6.0 |
| | With vibrations or impacts | 6.0 to 10.0 |

*The reference values of the static safety factor may vary depending on usage conditions such as environment, lubrication status, mounting surface accuracy, and/or rigidity.

$$f_s = \frac{C_0}{P_{\max}} \dots\dots (1)$$

f_s : Static safety factor
 C_0 : Basic static load rating (N)
 P_{\max} : Maximum applied load (N)

Nominal Life and Service Life Time

Calculating the Nominal Life

The nominal life (L_{10}) is obtained from the following formulas using the basic dynamic load rating (C) and the calculated load acting on the LM Guide (P_c). For this calculation, the basic dynamic load is to be based on a nominal life of 50 km in case of an LM Guide with balls, or 100 km in case of an LM Guide with rollers.

- LM Guide with balls (Using a basic dynamic load rating based on a nominal life of 50 km)

$$L_{10} = \left(\frac{C}{P_c} \right)^3 \times 50 \dots\dots (2)$$

L_{10} : Nominal life (km)
 C : Basic dynamic load rating (N)
 P_c : Calculated load (N)

- LM Guide with rollers (Using a basic dynamic load rating based on a nominal life of 100 km)

$$L_{10} = \left(\frac{C}{P_c} \right)^{\frac{10}{3}} \times 100 \dots\dots (3)$$

*These nominal life formulas may not apply if the length of the stroke is less than or equal to twice the length of the LM block.

When comparing the nominal life (L_{10}), you must take into account whether the basic dynamic load rating was defined based on 50 km or 100 km. Convert the basic dynamic load rating based on ISO 14728-1 as necessary.

ISO-regulated basic dynamic load rating conversion formulas:

- LM Guide with balls

$$C_{100} = \frac{C_{50}}{1.26}$$

- LM Guide with rollers

$$C_{100} = \frac{C_{50}}{1.23}$$

C_{50} : Basic dynamic load based on a nominal life of 50 km
 C_{100} : Basic dynamic load based on a nominal life of 100 km

Calculating the Modified Nominal Life

During use, an LM Guide may be subjected to vibrations and shocks as well as fluctuating loads, which are difficult to detect. In addition, the surface hardness of the raceways, the operating temperature, and having LM blocks arranged directly behind one another will have a decisive impact on the service life.

Taking these factors into account, the modified nominal life (L_{10m}) can be calculated according to the following formulas (4) and (5).

- Modified factor α

$$\alpha = \frac{f_H \cdot f_T \cdot f_C}{f_W}$$

α : Modified factor
 f_H : Hardness factor (See the general catalog for details)
 f_T : Temperature factor (See the general catalog for details)
 f_C : Contact factor (See the general catalog for details)
 f_W : Load factor (See the general catalog for details)

- Modified nominal life L_{10m}

- LM Guide with balls

$$L_{10m} = \left(\alpha \times \frac{C}{P_c} \right)^3 \times 50 \dots\dots (4)$$

- LM Guide with rollers

$$L_{10m} = \left(\alpha \times \frac{C}{P_c} \right)^{\frac{10}{3}} \times 100 \dots\dots (5)$$

L_{10m} : Modified nominal life (km)
 C : Basic dynamic load rating (N)
 P_c : Calculated load (N)

Once the nominal life (L_{10}) has been obtained, the service life time can be obtained using the following formula if the stroke length and the number of cycles are constant.

$$L_h = \frac{L_{10} \times 10^6}{2 \times l_s \times n_1 \times 60}$$

L_h : Service life time (h)
 l_s : Stroke length (mm)
 n_1 : Cycles per minute (min⁻¹)

Handling

- (1) Please use at least two people to move any product weighing 20 kg or more, or use a dolly or another method of conveyance. Otherwise, it may cause injury or damage the unit.
- (2) Do not disassemble the parts. This will result in loss of functionality.
- (3) Tilting an LM block or LM rail may cause them to fall by their own weight.
- (4) Take care not to drop or strike the LM Guide. Otherwise, it may cause injury or damage the unit. Even if there is no outward indication of damage, a sudden impact could prevent the unit from functioning properly.
- (5) When installing the LM Guide, be sure not to remove the LM block from the LM rail.
- (6) Placing a hand inside the LM rail mounting hole may lead to the hand being caught between the block and rail and cause injury.
- (7) Wear appropriate safety gear, such as protective gloves and safety shoes, when handling the product.

Precautions on Use

- (1) Prevent foreign materials, such as cutting chips or coolant, from entering the product. Failure to do so could damage the product.
- (2) Prevent foreign materials, such as cutting chips, coolant, corrosive solvents, or water from getting in the product by using a bellows or cover when the product is used in an environment where such a thing is likely.
- (3) Do not use this product if the external temperature exceeds 80°C. If used in excess of this temperature, there is a risk that the resin and rubber parts may deform or become damaged (except for the heat-resistant type).
- (4) If foreign materials such as cutting chips adhere to the product, replenish the lubricant after washing the product.
- (5) Very small strokes can inhibit the formation of an oil film between the raceways and the area of contact for the rollers, resulting in fretting. Therefore, be sure to use a type of grease with high fretting resistance properties if the stroke will be small. We recommend periodically allowing the LM block to stroke a distance roughly equal to its length to help ensure that a film forms between the raceways and rollers.
- (6) Do not forcibly drive a pin, key, or other positioning device into the product. This could create indentations on the rolling surface and impair the product's function.
- (7) If the operation requires the block to be removed, please use a removing/mounting jig. (The removing/mounting jig is not provided as standard. To obtain one, please contact THK.)
- (8) When using a removing/mounting jig, align the ends of the LM rail and the jig and mount the block when the jig and rail are in parallel.
- (9) Mounting the block while it is tilted can lead to contamination by foreign materials, damage to internal components, or dropped rollers.
- (10) Inserting and using the LM block on the LM rail while rollers are missing could lead to premature failure of the product.
- (11) If any balls fall out of the LM block, contact THK. Do not use the product in that condition.
- (12) If the LM Guide breaks due to an accident or other cause, the block may get dislodged from the rail and fall. For the safe use of these products, take precautions such as adding a mechanism to prevent blocks from falling.
- (13) If the mounting material lacks sufficient rigidity or accuracy, the bearing load may be focused in one area, and bearing functionality will dramatically decrease. Therefore, carefully consider the rigidity and accuracy of the housing and base, and the strength of the securing bolts.
- (14) If you will be removing the LM block from the LM rail and then replacing the block, an LM block mounting/removing jig that facilitates such installation is available. Contact THK for details.

Lubrication

- (1) Thoroughly wipe off anti-rust oil and feed lubricant before using the product.
- (2) Do not mix different lubricants. Even grease containing the same type of thickening agent may, if mixed, interact in an adverse manner due to disparate additives or other ingredients.
- (3) When using the product in locations exposed to constant vibrations or in special environments such as in clean rooms, vacuums, and low/high temperatures, use a lubricant suitable for its use/environment.
- (4) When lubricating products that do not feature a grease nipple or oil hole, directly coat the raceways with lubricant and perform several warm-up strokes to ensure that the grease permeates the interior.
- (5) Grease viscosity can vary depending on the temperature. Please keep in mind that the LM Guide's sliding resistance may be affected by changes in viscosity.
- (6) After lubrication, sliding resistance of the LM Guide may increase due to the stirring resistance of the grease. Be sure to perform a warm-up operation and allow the grease to break in sufficiently before operating the machinery.
- (7) Excess grease may spatter after lubrication. Wipe off spattered grease as necessary.
- (8) Grease deteriorates over time, which decreases the lubricity, so perform regular grease inspections and replenish grease based on frequency of use.
- (9) How often grease should be replenished varies depending on the usage conditions and environment. We recommend greasing the system approximately every 100 km traveled (3 to 6 months). Final greasing interval/amount should be set at an actual machine.
- (10) The lubricant may not reach the raceway if the LM Guide is not installed in a horizontal orientation.
- (11) When adopting oil lubrication, the lubricant may not be distributed throughout the LM system depending on the mounting orientation of the LM block. Contact THK for details.

Storage

When storing the LM Guide, pack it as designated by THK and store it indoors in a horizontal position away from high or low temperatures and high humidity.

Please note that if the product has been kept in storage for an extended period, the lubricant inside may have deteriorated. Please ensure that you replenish the lubricant before using.

Disposal

Recommended Products

Caged Roller LM Guide

SRG

- Ultra-high rigidity
- Global standard size
- Wide array of options
- Long-term maintenance-free operation

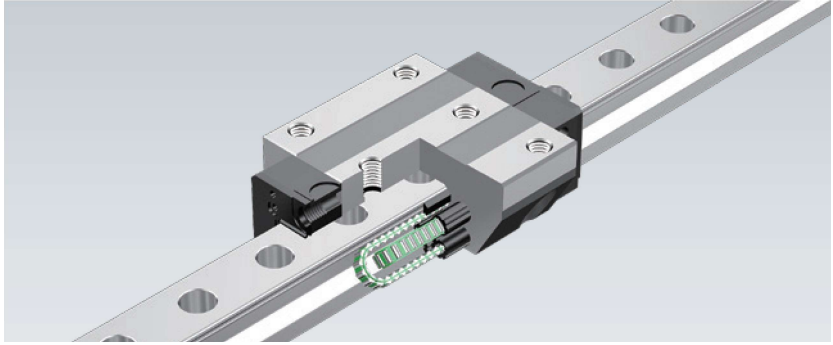

Caged Roller LM Guide

SRN

- Ultra-high rigidity
- Thin, low center of gravity type with lower product height than the SRG
- Long-term maintenance-free operation

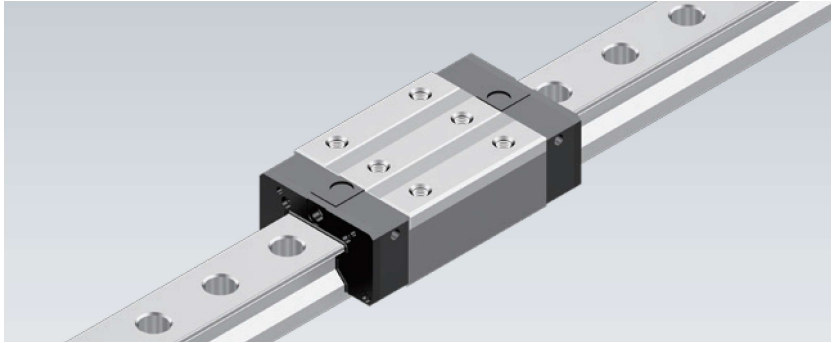

4-Way Equal Load Roller Type LM Guide HRX

●“LM Guide” and “” are registered trademarks of THK CO., LTD.

- The actual products may differ from the pictures and photographs in this catalog.
- Outward appearances and specifications are subject to change without notice for the purpose of improvement. Please consult with THK before using.
- Although great care has been taken in the production of this catalog, THK will not take any responsibility for damage resulting from typographical errors or omissions.
- For exports of our products and technologies and sales for export, our basic policy is to comply with the Foreign Exchange and Foreign Trade Act and other laws and regulations. Please consult us in advance if you want to export our products by the piece.

All rights reserved

THK CO., LTD.

Headquarters 2-12-10 Shibaura, Minato-ku, Tokyo 108-8506 Japan

International Sales Department Phone: +81-3-5730-3860

www.thk.com
